



THERMODYNE STEAM TRAP

MODEL P46SS

THERMODYNAMIC DISC TRAP WITH THERMOSTATIC AIR VENTING

Benefits

Stainless steel durability for steam mains and tracing.

1. Hardened working surfaces for long life.
2. Lapped disc provides steam-tight seal without air binding for long life.
3. Quick thermostatic air venting with bimetal ring for fast start-up.
4. Air jacketing reduces cycling and extends life.
5. Built-in, easy-to-clean screen.



Specifications

Model	P46SS	
Connection	Screwed	
Size (in)	1/2, 3/4	
Maximum Operating Pressure (psig) PMO	650	
Minimum Operating Pressure (psig)	Horizontally installed: 3.5	Vertically installed: 6
Maximum Operating Temperature (°F) TMO	800	
Maximum Allowable Pressure (psig) PMA	650	
Maximum Allowable Temperature (°F) TMA	800	
Maximum Back Pressure	80% of Inlet Pressure	



CAUTION

To avoid abnormal operation, accidents or serious injury, DO NOT use this product outside of the specification range. Local regulations may restrict the use of this product to below the conditions quoted.

Connections and sizes in bold are standard

No.	Description	Material	ASTM/AISI*	JIS
①	Body	Stainless Steel	AISI420	SUS420J2
②	Cover	Stainless Steel	AISI420F2	SUS420F2
③	Nameplate	Stainless Steel	AISI304	SUS304
④	Disc	Stainless Steel	AISI420	SUS420J2
⑤	Screen	Stainless Steel	AISI430	SUS430
⑥	Screen Holder Gasket	Stainless Steel	AISI316L	SUS316L
⑦	Screen Holder	Stainless Steel	AISI303	SUS303
⑧	Cap	Stainless Steel	AISI304	SUS304
⑨	Air Vent Ring	Bimetal	—	—
⑩	Disc Holder Ring	Stainless Steel	AISI420F2	SUS420F2

* Equivalent

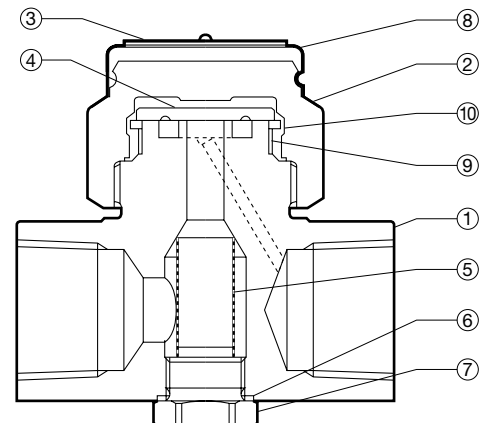

Dimensions

● **P46SS** Screwed

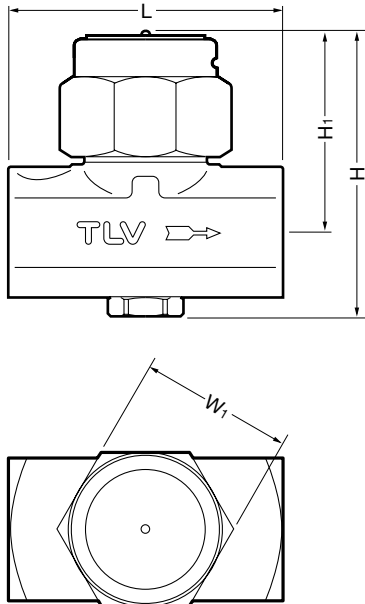

P46SS Screwed* (in)

Size	L	H	H ₁	W ₁	Weight (lb)
1/2	2 3/4	2 15/16	2 1/16	1 1/2	1.0
3/4					

* NPT, other standards available

Discharge Capacity

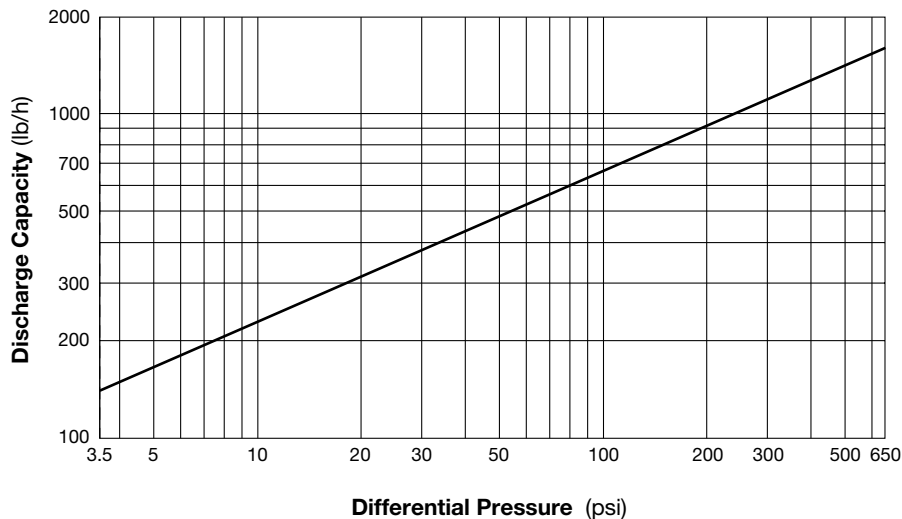

1. Differential pressure is the difference between the inlet and outlet pressure of the trap.
2. Recommended safety factor: at least 2.

TLV CORPORATION

13901 South Lakes Drive, Charlotte, NC 28273-6790
 Phone: 704-597-9070 Fax: 704-583-1610
 E-mail: tlv@tlvengineering.com
 For Technical Service 1-800 "TLV TRAP"



Manufacturer

TLV® CO., LTD.

Kakogawa, Japan

is approved by LRQA Ltd. to ISO 9001/14001

ISO 9001/ISO 14001

